

1 **EU - TYPE EXAMINATION CERTIFICATE**

2 **Equipment or Protective System Intended for use in Potentially Explosive Atmospheres  
Directive 2014/34/EU**

3 EU - Type Examination Certificate Number: **SGS20ATEX0049X**

4 Product: **XTV Range of Trace Heating Systems**

5 Manufacturer: **nVent Thermal LLC**

6 Address: **899 Broadway Street, CA, 94063-3104, United States of America**

7 This product and any acceptable variation thereto is specified in the schedule to this certificate and the documents therein referred to.

8 SGS Fimko Oy, Notified Body number 0598, in accordance with Article 17 of Directive 2014/34/EU of the European Parliament and of the Council, dated 26 February 2014, certifies that this product has been found to comply with the Essential Health and Safety Requirements relating to the design and construction of products intended for use in potentially explosive atmospheres given in Annex II to the Directive.

The examination and test results are recorded in confidential Report No. **GB/BAS/ExTR20.0030/00**

9 Compliance with the Essential Health and Safety Requirements has been assured by compliance with:

**EN 60079-0: 2012 + A11: 2013      EN IEC 60079-7: 2015 + A1: 2018      EN 60079-18: 2015 + A1: 2017**  
**EN 60079-30-1: 2017      EN 60079-31: 2014**

except in respect of those requirements listed at item 18 of the Schedule.

10 If the sign "X" is placed after the certificate number, it indicates that the product is subject to the Specific Conditions of Use specified in the schedule to this certificate.

11 This EU - TYPE EXAMINATION CERTIFICATE relates only to the design and construction of the specified product. Further requirements of the Directive apply to the manufacturing process and supply of this product. These are not covered by this certificate.

12 The marking of the product shall include the following :

**⊕ II 2 GD Ex 60079-30-1 eb IIC T\* Gb or Ex 60079-30-1 eb mb IIC T\* Gb      Tmin -60°C**  
**Ex 60079-30-1 tb IIIC T\*\*°C Db or Ex 60079-30-1 eb mb IIIC T\*\*°C Db      (\* See Schedule)**

SGS Fimko Oy Customer Reference No. **865**

Project File No. **19/0329**

This document is issued by the Company subject to their General Conditions for Certification Services accessible at <http://www.sgs.com/en/Terms-and-Conditions.aspx> . Attention is drawn to the limitation of liability, indemnification and jurisdiction issues defined therein. Any holder of this document is advised that information contained herein reflects the Company's findings at the time of their intervention only and within the limits of Client's instructions, if any. It does not necessarily indicate that the equipment may be used in particular industries or circumstances. The Company's sole responsibility is to its Client and this document does not exonerate parties to a transaction from exercising all their rights and obligations under the transaction documents. This document cannot be reproduced except in full, schedule included, without prior written approval of the Company. Any unauthorized alteration, forgery or falsification of the content or appearance of this document is unlawful and offenders may be prosecuted to the fullest extent of the law.

**SGS Fimko Oy**  
Takomotie 8  
FI-00380 Helsinki, Finland  
Telephone +358 (0)9 696 361  
e-mail [sgs.fimko@sgs.com](mailto:sgs.fimko@sgs.com)  
web site [www.sgs.fi](http://www.sgs.fi)

Business ID 0978538-5 Member of the SGS Group (SGA SA)



**R S SINCLAIR**  
Authorised Signatory for SGS Fimko Oy

13

## Schedule

14

### Certificate Number SGS20ATEX0049X

#### 15 Description of Product

The XTV Range of Trace Heating Systems is of the parallel circuit self-regulating type, rated at up to 277V, with power output up to 66W/m (20W/ft). The XTV trace heating cables have a maximum self-limiting temperature of 240°C. The systems are also suitable for applications at lower temperatures when used as part of a stabilised design. The limiting temperatures of the end seals, splices and power connections must be observed as part of the self-limiting or stabilised design.

Each trace heating system comprises:

- the active heating cable.
- an end seal for terminating the remote end of the unit.
- a cable gland for connecting the powered end of the unit to a suitable terminal enclosure, or alternative integrated power connection systems.

The active heating cable comprises two stranded copper conductors separated by a fluoropolymer spacer around which are wound, in a spiral, a number of carbon loaded polymer fibres, which form the active part of the heating cable. An extruded layer of fluoropolymer covers the fibres and serves to insulate the copper conductors from a conductive covering, which covers the basic heater. A protective anti-corrosion fluoropolymer sheath may be extruded over the conductive cover. In this arrangement the unit is designated the XTV-CT Range of Trace Heating Systems.

The outer fluoropolymer sheath may optionally be omitted to form the XTV-C Range of Trace Heating Systems.

The declared maximum withstand temperature for the range is 250°C and the minimum installation temperature is -60°C.

#### CABLE ACCESSORIES

##### END SEALS

The end seals for terminating the remote end of the unit may be the following types:

Types E-100-L or E-100, which are mechanical end seals incorporating an end cap which is filled with silicone grease sealant, covered by certificates Sira14ATEX3015X and PTB09ATEX1060U.

Types E-100-L-A or E-100-A, which are mechanical end seals incorporating an end cap which is filled with silicone grease sealant.

A Raychem Type E-40 heat shrink end seal kit.

##### SPLICES AND JOINTS

The following splicing and jointing arrangements are provided:

A Raychem Type S-40 heat shrink splice kit for connecting lengths of active heating cable.

A Raychem T-100 tee connection system, certificate PTB20ATEX1008U, for connecting up to three heater cables.

#### POWER CONNECTIONS

Power connection may be achieved by the following means:

Connection Type	ATEX Certificate
JBM-100	PTB20ATEX1008U
JBS-100	PTB20ATEX1008U
JBU-100	PTB20ATEX1008U
C25-21 Connection Kit	Baseefa16ATEX0037U
C25-100 Connection Kit	Baseefa16ATEX0038U
C25-100-Metal / C3/4-100-Metal / C25-100-Metal-NP / C3/4-100-Metal-NP / C25-100-Metal-SS Kits	Baseefa16ATEX0039U

The C25-100-Metal / C3/4-100-Metal / C25-100-Metal-NP / C3/4-100-Metal-NP / C25-100-Metal-SS Kits include M25 or ¾ NPT gland to Sira01ATEX1270X and core sealer to Baseefa15ATEX0194U.

A number of power levels and voltages, up to the maximum specified, are included in the range. They are identified in the following manner:

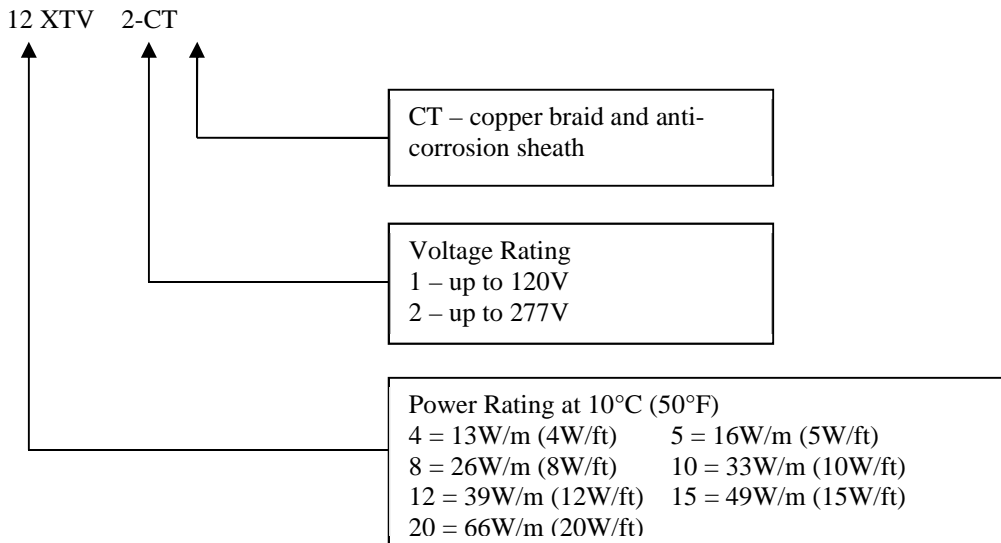

The following temperature classes are assigned:

Output (W/ft)	Type	Temperature Class
4 , 8 & 12	XTV2	T3
5 & 10	XTV1 & XTV2	T3
15	XTV1	230°C (T2)
15	XTV2	T3
20	XTV1	230°C (T2)
20	XTV2	240°C (T2)

Any of the products in the range may be considered as part of a stabilised design system. In such a system the design is based upon the use of nVent proprietary software Trace calc Pro. The algorithm defined in this software may be used in additional design software. These designs may carry temperature classes other than those described above and are marked with the actual maximum temperature and the appropriate T class in parenthesis.

The minimum bending radii for XTV trace heating cable at specific temperatures are shown in the table below:

Temperature, T (°C)	Minimum Bending Radius (mm)
$-60 \leq T < -20$	51
$-20 \leq T < -10$	35
$-10 \leq T < 0$	25
$0 \leq T < +10$	20
$T \geq +10$	12

## 16 Report Number

SGS Baseefa certification report GB/BAS/ExTR20.0030/00

## 17 Specific Conditions of Use

- The limiting temperatures for the end seals, splices and power connections are:  
260°C for the E-40 and S-40  
151°C for the E-100, E-100-L and JBS-100  
155°C for the JBM-100 and T-100  
110°C for the C25-21 and C25-100  
180°C for the C25-100-Metal / C3/4-100-Metal

The E-100, E-100-L, JBM-100, JBM-100-L, JBS-100, JBS-100-L and T-100 have limiting temperatures based on an internal component in these accessories. When located on a pipe or other work piece surface, a maximum pipe temperature of 250°C will not cause the limiting temperatures of 151°C or 155°C to be exceeded.

- The end seals, splices and power connections have the following associated ambient temperatures.  
-60°C to +56°C for the E-40 and S-40  
-55°C to +56°C for the T-100, JBM-100, JBS-100 and JBU-100  
-50°C to +56°C for the E-100  
-40°C to +56°C for the JBS-100-L, JBM-100-L and JBU-100-L  
-40°C to +40°C for the E-100-L  
-55°C to +110°C for the C25-21 and C25-100  
-50°C to +180°C for the C25-100-Metal / C3/4-100-Metal / C25-100-Metal-NP / C3/4-100-Metal-NP / C25-100-Metal-SS
- The assembly of glands, splices and end terminations shall be carried out in accordance with the manufacturer's instructions.
- The heating element supply circuit must include an electrical protection device in conformity with clause 4.3 of EN 60079-30-1. For the JBM-100-L, JBU-100-L and JBS-100-L this shall be limited to 20A maximum when used at ambient temperatures above 40°C.
- The minimum installation temperature is -60°C. The minimum bending radii at specific temperatures for the Type XTV units are shown in the table in the equipment description.
- The supply to the heating unit must be terminated in a suitably certified terminal enclosure.
- At ambient temperatures above 40°C temperature resistant power cable suitable for temperatures above 90°C and metal glands must be used.
- When the E-100-L is used in ambient temperatures above 40°C metal nameplates must be used.
- The installer is to carry out a dielectric strength test on Ex equipment in which the C25-21, C25-100 and C25-100-Metal / C3/4-100-Metal / C25-100-Metal-NP / C3/4-100-Metal-NP / C25-100-Metal-SS connection kit is fitted. No dielectric breakdown shall occur. (Alternatively an insulation resistance test may be undertaken in accordance with EN 60079-30-2).

## 18 Essential Health and Safety Requirements

In addition to the Essential Health and Safety Requirements (EHSRs) covered by the standards listed at item 9, the following are considered relevant to this product, and conformity is demonstrated in the report:

Clause	Subject
1.2.7	LVD type requirements
1.2.8	Overloading of equipment (protection relays, etc.)
1.4.1	External effects
1.4.2	Aggressive substances, etc.

## 19 Drawings and Documents

Number	Sheet	Issue	Date	Description
906567-A <sup>i</sup>	1 of 1	O	05/10/18	C25-21,C25-100 and C25-100-METAL-XX, C3/4-100-METAL-XX Connection Kits
906794-A <sup>ii</sup>	1 of 1	AA	03/30/20	Generic ATEX and IECEx Print Dwg For BTV-CT, QTVR-CT, XTV-CT, KTV-CT Heating Cables
906521-A <sup>iii</sup>	1 of 1	H	05/10/18	XTV-CT
907825-A <sup>iii</sup>	1 of 1	D	09/03/20	XTV-C
907826-A <sup>iii</sup>	1 of 1	E	28-FEB-2018	XTV-C Label
906576-A <sup>iii</sup>	1 of 1	N	8/11/20	XTV Heater Units (European System)
906817-A <sup>iv</sup>	1 of 1	L	08/11/20	ATEX Stabilized Design Labels
9242869 <sup>i</sup>	1 & 2	O	12/09/19	LABL-JBM-100-L-E
9532687 <sup>i</sup>	1 & 2	Q	12/09/19	LABL-JBM-100-L-EP
9621473 <sup>i</sup>	1 & 2	O	12/09/19	LABL-JBS-100-L-E
9777523 <sup>i</sup>	1 & 2	P	12/09/19	LABL-JBS-100-L-EP
9319676 <sup>i</sup>	1 & 2	O	12/09/19	LABL-JBU-100-L-E
9735898 <sup>i</sup>	1 & 2	O	12/09/19	LABL-JBU-100-L-EP
908758-A <sup>v</sup>	1 & 2	A	3/20/20	E-40 Heat Shrinkable End Seal Kit Cut Back Dimensions
908782-A <sup>iv</sup>	1 of 1	A	3/20/20	S-40 Heat Shrinkable Splice Joint Kit Cut Back Dimensions for XTV and KTV

- i) These drawings are common to IECEx BAS 20.0008X, IECEx BAS 20.0011X, IECEx BAS 20.0012X, IECEx BAS 20.0013X, IECEx BAS 20.0014X, SGS20ATEX0045X, SGS20ATEX0048X, SGS20ATEX0049X, SGS20ATEX0050X, SGS20ATEX0051X and are held with IECEx BAS 20.0008X.
- ii) These drawings are common to IECEx BAS 20.0011X, IECEx BAS 20.0012X, IECEx BAS 20.0013X, IECEx BAS 20.0014X, SGS20ATEX0048X, SGS20ATEX0049X, SGS20ATEX0050X, SGS20ATEX0051X and are held with IECEx BAS 20.0011X.
- iii) These drawings are common to IECEx BAS 20.0012X, SGS20ATEX0049X and are held with IECEx BAS 20.0012X.
- iv) These drawings are common to IECEx BAS 20.0012X, IECEx BAS 20.0014X, SGS20ATEX0049X, SGS20ATEX0051X and are held with IECEx BAS 20.0012X.
- v) These drawings are common to IECEx BAS 20.0008X, IECEx BAS 20.0012X, IECEx BAS 20.0014X, SGS20ATEX0045X, SGS20ATEX0049X, SGS20ATEX0051X and are held with IECEx BAS 20.0008X.

1 **EU - TYPE EXAMINATION CERTIFICATE**

2 **Equipment or Protective System Intended for use in Potentially Explosive Atmospheres  
Directive 2014/34/EU**

3 EU - Type Examination Certificate Number: **SGS20ATEX0049X – Issue 1**

4 Product: **XTV Range of Self-Regulating Trace Heating Systems**

5 Manufacturer: **nVent Thermal LLC**

6 Address: **899 Broadway Street, CA, 94063-3104, United States of America**

7 This re-issued certificate extends EU Type Examination Certificate No. **SGS20ATEX0049X** to apply to product designed and constructed in accordance with the specification set out in the Schedule of the said certificate but having any variations specified in the Schedule attached to this certificate and the documents therein referred to.

8 SGS Fimko Oy, Notified Body number 0598, in accordance with Article 17 of Directive 2014/34/EU of the European Parliament and of the Council, dated 26 February 2014, certifies that this product has been found to comply with the Essential Health and Safety Requirements relating to the design and construction of products intended for use in potentially explosive atmospheres given in Annex II to the Directive.

The examination and test results are recorded in confidential Report No. See Certificate History

9 Compliance with the Essential Health and Safety Requirements has been assured by compliance with:

**EN IEC 60079-0:2018**                      **EN IEC 60079-7:2015+A1:2018**                      **EN 60079-18:2015+A1:2017**  
**EN 60079-30-1:2017**                      **EN 60079-31:2014**

except in respect of those requirements listed at item 18 of the Schedule.

10 If the sign “X” is placed after the certificate number, it indicates that the product is subject to the Specific Conditions of Use specified in the schedule to this certificate.

11 This EU - TYPE EXAMINATION CERTIFICATE relates only to the design and construction of the specified product. Further requirements of the Directive apply to the manufacturing process and supply of this product. These are not covered by this certificate.

12 The marking of the product shall include the following :

**Ex II 2 GD Ex 60079-30-1 eb IIC T\* Gb**      or      **Ex 60079-30-1 eb mb IIC T\* Gb**      **T<sub>min</sub> -60°C**  
**Ex 60079-30-1 tb IIIC T\*\*°C Db**      or      **Ex 60079-30-1 mb tb IIIC T\*\*°C Db**      **(\*/\*\* See Schedule)**

SGS Fimko Oy Customer Reference No. **865**

Project File No. **20/0676**

This document is issued by the Company subject to their General Conditions for Certification Services accessible at <http://www.sgs.com/en/Terms-and-Conditions.aspx>. Attention is drawn to the limitation of liability, indemnification and jurisdiction issues defined therein. Any holder of this document is advised that information contained herein reflects the Company’s findings at the time of their intervention only and within the limits of Client’s instructions, if any. It does not necessarily indicate that the equipment may be used in particular industries or circumstances. The Company’s sole responsibility is to its Client and this document does not exonerate parties to a transaction from exercising all their rights and obligations under the transaction documents. This document cannot be reproduced except in full, schedule included, without prior written approval of the Company. Any unauthorized alteration, forgery or falsification of the content or appearance of this document is unlawful and offenders may be prosecuted to the fullest extent of the law.

**SGS Fimko Oy**  
Takomotie 8  
FI-00380 Helsinki, Finland  
Telephone +358 (0)9 696 361  
e-mail [sgs.fimko@sgs.com](mailto:sgs.fimko@sgs.com)  
web site [www.sgs.fi](http://www.sgs.fi)

Business ID 0978538-5 Member of the SGS Group (SGA SA)



**R S SINCLAIR**  
Authorised Signatory for SGS Fimko Oy

13

## **Schedule**

14

### **Certificate Number SGS20ATEX0049X – Issue 1**

#### **15 Description of Product**

The XTV Range of Self-Regulating Trace Heating Systems is of the parallel circuit self-regulating type, rated at up to 277V, with power output up to 66W/m (20W/ft). The units have a maximum self-limiting temperature of 240°C. The systems are also suitable for applications at lower temperatures when used as part of a stabilised design. The limiting temperatures of the end seals, splices and power connections must be observed as part of the self-limiting or stabilised design.

Each trace heating system comprises:

- the active heating cable.
- an end seal for terminating the remote end of the unit.
- a cable gland for connecting the powered end of the unit to a suitable terminal enclosure, or alternative integrated power connection systems.

The active heating cable comprises two stranded copper conductors separated by a fluoropolymer spacer around which are wound, in a spiral, a number of carbon loaded polymer fibres, which form the active part of the heating cable. An extruded layer of fluoropolymer covers the fibres and serves to insulate the copper conductors from a conductive covering, which covers the basic heater. A protective anti-corrosion fluoropolymer sheath may be extruded over the conductive cover. In this arrangement the unit is designated the XTV-CT Range of Self-Regulating Trace Heating Systems.

The outer fluoropolymer sheath may optionally be omitted to form the XTV-C Range of Self-Regulating Trace Heating Systems.

The declared maximum withstand temperature for the range is 250°C and the minimum installation temperature is -60°C.

#### **CABLE ACCESSORIES**

##### **END SEALS**

The end seals for terminating the remote end of the unit may be the following types:

Types E-100-L or E-100, which are mechanical end seals incorporating an end cap which is filled with silicone grease sealant, covered by certificates Sira14ATEX3015X and PTB09ATEX1060U.

Types E-100-L-A or E-100-A, which are mechanical end seals incorporating an end cap which is filled with silicone grease sealant.

A Raychem Type E-40 heat shrink end seal kit.

Type E-150 mechanical end seals, covered by certificate DEKRA20ATEX0011U.

##### **SPLICES AND JOINTS**

The following splicing and jointing arrangements are provided:

A Raychem Type S-40 heat shrink splice kit for connecting lengths of active heating cable.

A Raychem T-100 tee connection system, certificate PTB20ATEX1008U, for connecting up to three heater cables.

Type S-150 mechanical splice kit, covered by DEKRA20ATEX0011U.

**POWER CONNECTIONS**

Power connection may be achieved by the following means:

Connection Type	ATEX Certificate
JBM-100	PTB20ATEX1008U
JBS-100	PTB20ATEX1008U
JBU-100	PTB20ATEX1008U
C-150-E	DEKRA20ATEX0011U
C25-21 Connection Kit	Baseefa16ATEX0037U
C25-100 Connection Kit	Baseefa16ATEX0038U
C25-100-Metal / C3/4-100-Metal / C25-100-Metal-NP / C3/4-100- Metal-NP / C25-100-Metal-SS Kits	Baseefa16ATEX0039U

The C25-100-Metal / C3/4-100-Metal / C25-100-Metal-NP / C3/4-100-Metal-NP / C25-100-Metal-SS Kits include M25 or ¾ NPT gland to Sira01ATEX1270X and core sealer to Baseefa15ATEX0194U.

A number of power levels and voltages, up to the maximum specified, are included in the range. They are identified in the following manner:

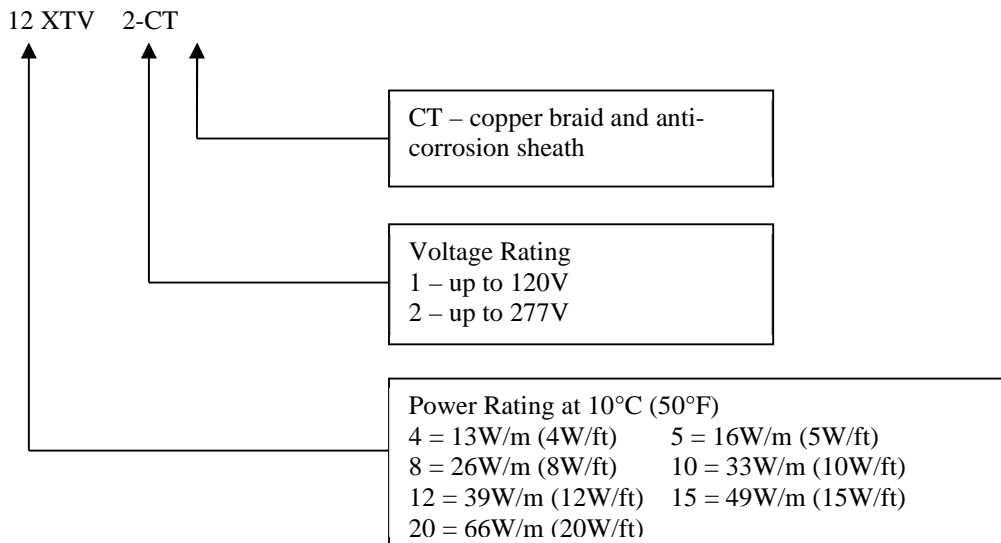

The following temperature classes are assigned:

Output (W/ft)	Type	Temperature Class
4, 8 & 12	XTV2	T3
5 & 10	XTV1 & XTV2	T3
15	XTV1	230°C (T2)
15	XTV2	T3
20	XTV1	230°C (T2)
20	XTV2	240°C (T2)

Any of the products in the range may be considered as part of a stabilised design system. In such a system the design is based upon the use of nVent proprietary software Trace calc Pro. The algorithm defined in this software may be used in additional design software. These designs may carry temperature classes other than those described above and are marked with the actual maximum temperature and the appropriate T class in parenthesis.

The minimum bending radii for XTV trace heating cable at specific temperatures are shown in the table below:



Temperature, T (°C)	Minimum Bending Radius (mm)
$-60 \leq T < -20$	51
$-20 \leq T < -10$	35
$-10 \leq T < 0$	25
$0 \leq T < +10$	20
$T \geq +10$	12

## 16 Report Number

See Certificate History.

## 17 Specific Conditions of Use

1. The limiting temperatures for the end seals, splices and power connections are:

260°C for the E-40 and S-40  
150°C for the C-150-E, S-150 and E-150  
151°C for the E-100, E-100-L and JBS-100  
155°C for the JBM-100 and T-100  
110°C for the C25-21 and C25-100  
180°C for the C25-100-Metal / C3/4-100-Metal

The E-100, E-100-L, JBM-100, JBM-100-L, JBS-100, JBS-100-L and T-100 have limiting temperatures based on an internal component in these accessories. When located on a pipe or other work piece surface, a maximum pipe temperature of 250°C will not cause the limiting temperatures of 151°C or 155°C to be exceeded.

2. The end seals, splices and power connections have the following associated ambient temperatures.

-60°C to +56°C for the E-40 and S-40  
-55°C to +56°C for the T-100, JBM-100, JBS-100, JBU-100 and E-100  
-40°C to +56°C for the JBS-100-L, JBM-100-L and JBU-100-L  
-55°C to +55°C for the C-150-E, S-150 and E-150  
-40°C to +40°C for the E-100-L  
-55°C to +110°C for the C25-21 and C25-100  
-60°C to +180°C for the C25-100-Metal / C3/4-100-Metal / C25-100-Metal-NP / C3/4-100-Metal-NP / C25-100-Metal-SS

3. The assembly of glands, splices and end terminations shall be carried out in accordance with the manufacturer's instructions.
4. The heating element supply circuit must include an electrical protection device in conformity with Clause 4.4 of EN 60079-30-1. For the JBM-100-L, JBU-100-L and JBS-100-L this shall be limited to 20A maximum when used at ambient temperatures above 40°C.
5. The minimum installation temperature is -60°C. The minimum bending radii at specific temperatures for the Type XTV units are shown in the table in the equipment description.
6. The supply to the heating unit must be terminated in a suitably certified terminal enclosure.
7. At ambient temperatures above 40°C temperature resistant power cable suitable for temperatures above 90°C and metal glands must be used.
8. When the E-100-L is used in ambient temperatures above 40°C metal nameplates must be used.
9. The installer is to carry out a dielectric strength test on Ex equipment in which the C25-21, C25-100 and C25-100-Metal / C3/4-100-Metal / C25-100-Metal-NP / C3/4-100-Metal-NP / C25-100-Metal-SS connection kit is fitted. No dielectric breakdown shall occur. (Alternatively, an insulation resistance test may be undertaken in accordance with EN 60079-30-2).

## 18 Essential Health and Safety Requirements

In addition to the Essential Health and Safety Requirements (EHSRs) covered by the standards listed at item 9, the following are considered relevant to this product, and conformity is demonstrated in the report:

Clause	Subject
1.2.7	LVD type requirements
1.2.8	Overloading of equipment (protection relays, etc.)
1.4.1	External effects
1.4.2	Aggressive substances, etc.

## 19 Drawings and Documents

New drawings submitted for this issue of certificate:

Number	Sheet	Issue	Date	Description
907826-A <sup>iii</sup>	1 of 1	F	01/22/21	XTV-C Label
906576-A <sup>iii</sup>	1 of 1	O	1/15/21	XTV Heater Units (European System)

Current drawings which remain unaffected by this issue:

Number	Sheet	Issue	Date	Description
906567-A <sup>i</sup>	1 of 1	O	05/10/18	C25-21, C25-100 and C25-100-METAL-XX, C3/4-100-METAL-XX Connection Kits
906794-A <sup>ii</sup>	1 of 1	AA	03/30/20	Generic ATEX and IECEx Print Dwg for BTV-CT, QTVR-CT, XTV-CT, KTV-CT Heating Cables
906521-A <sup>iii</sup>	1 of 1	H	05/10/18	XTV-CT
907825-A <sup>iii</sup>	1 of 1	D	09/03/20	XTV-C
906817-A <sup>iv</sup>	1 of 1	L	08/11/20	ATEX Stabilised Design Labels
9242869 <sup>v</sup>	1 & 2	O	12/09/19	LABL-JBM-100-L-E
9532687 <sup>v</sup>	1 & 2	Q	12/09/19	LABL-JBM-100-L-EP
9621473 <sup>v</sup>	1 & 2	O	12/09/19	LABL-JBS-100-L-E
9777523 <sup>v</sup>	1 & 2	P	12/09/19	LABL-JBS-100-L-EP
9319676 <sup>v</sup>	1 & 2	O	12/09/19	LABL-JBU-100-L-E
9735898 <sup>v</sup>	1 & 2	O	12/09/19	LABL-JBU-100-L-EP
908758-A <sup>vi</sup>	1 & 2	A	3/20/20	E-40 Heat Shrinkable End Seal Kit Cut Back Dimensions
908782-A <sup>iv</sup>	1 of 1	A	3/20/20	S-40 Heat Shrinkable Splice Joint Kit Cut Back Dimensions for XTV and KTV

- i) These drawings are common to IECEx BAS 20.0008X, IECEx BAS 20.0009X, IECEx BAS 20.0011X, IECEx BAS 20.0012X, IECEx BAS 20.0013X, IECEx BAS 20.0014X, SGS20ATEX0045X, SGS20ATEX0046X, SGS20ATEX0048X, SGS20ATEX0049X, SGS20ATEX0050X, SGS20ATEX0051X and are held with IECEx BAS 20.0008X.
- ii) These drawings are common to IECEx BAS 20.0011X, IECEx BAS 20.0012X, IECEx BAS 20.0013X, IECEx BAS 20.0014X, SGS20ATEX0048X, SGS20ATEX0049X, SGS20ATEX0050X, SGS20ATEX0051X and are held with IECEx BAS 20.0011X.
- iii) These drawings are common to IECEx BAS 20.0012X, SGS20ATEX0049X and are held with IECEx BAS 20.0012X.
- iv) These drawings are common to IECEx BAS 20.0012X, IECEx BAS 20.0014X, SGS20ATEX0049X, SGS20ATEX0051X and are held with IECEx BAS 20.0012X.
- v) These drawings are common to IECEx BAS 20.0008X, IECEx BAS 20.0011X, IECEx BAS 20.0012X, IECEx BAS 20.0013X, IECEx BAS 20.0014X, SGS20ATEX0045X, SGS20ATEX0048X, SGS20ATEX0049X, SGS20ATEX0050X, SGS20ATEX0051X and are held with IECEx BAS 20.0008X.
- vi) These drawings are common to IECEx BAS 20.0008X, IECEx BAS 20.0012X, IECEx BAS 20.0014X, SGS20ATEX0045X, SGS20ATEX0049X, SGS20ATEX0051X and are held with IECEx BAS 20.0008X.

20 Certificate History

Certificate No.	Date	Comments
SGS20ATEX0049X	23 October 2020	The release of the prime certificate. The associated test and assessment against the requirements of EN 60079-0:2012+A11:2013, EN IEC 60079-7:2015+A1:2018, EN 60079-18:2015+A1:2017, EN 60079-30-1:2017 and EN 60079-31:2014 is documented in Test Report No. GB/BAS/ExTR20.0030/00.
SGS20ATEX0049X Issue 1	11 February 2021	To assess the XTV range of self-regulating trace heating systems against EN IEC 60079-0:2018, introduce the low profile power connection, splice and end seal kits, types C-150-E, S-150 and E-150 afforded DEKRA20ATEX0011U, minor amendments to the product description, to change the product name to “XTV Range of Self-Regulating Trace Heating Systems” and to amend the Specific Conditions of Use. The associated test and assessment is documented in Test Report No. GB/BAS/ExTR21.0005/00.

For drawings applicable to each issue, see original of that issue.