

Self-regulating heating cable

HEATING CABLE CONSTRUCTION

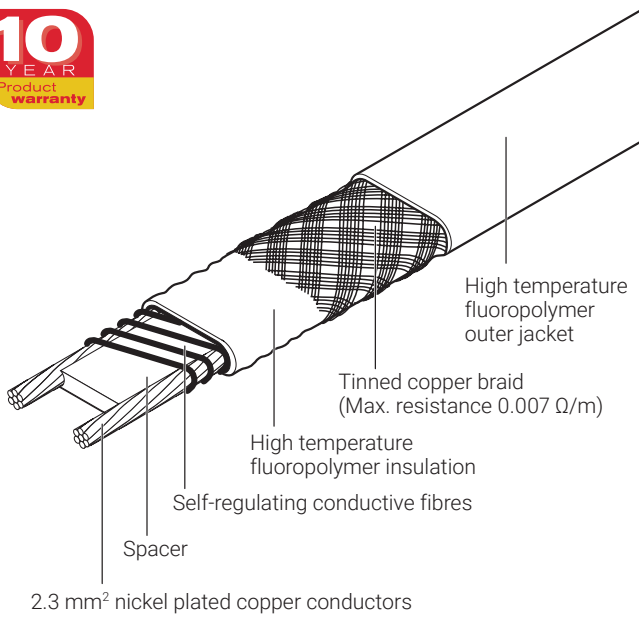

Electrical heat-tracing for process temperature maintenance applications up to 150°C which may be subject to steam cleaning.

The nVent RAYCHEM KTV family of self-regulating, parallel circuit heating cables is used for process temperature maintenance of pipes and vessels.

It can also be used for frost protection of large pipes and for applications requiring high temperature exposure capability.

APPLICATION

Area classification	Hazardous, Zone 1, Zone 2 (Gas), Zone 21, Zone 22 (Dust) Ordinary
Traced surface type	Carbon steel Stainless steel Painted or unpainted metal
Chemical resistance	Organics and corrosives For aggressive organics and corrosives consult your local nVent representative

SUPPLY VOLTAGE

230 Vac (Contact your local nVent representative for data on other voltages)

APPROVALS (*)

SGS20ATEX0051X

II 2 G Ex 60079-30-1 eb IIC 226°C(T2) Gb or Ex 60079-30-1 eb mb IIC 226°C(T2) Gb

II 2 D Ex 60079-30-1 tb IIIC T226°C Db or Ex 60079-30-1 mb tb IIIC T226°C Db

Tmin -60°C

IECEX BAS 20.0014X

Ex 60079-30-1 eb IIC 226°C(T2) Gb or Ex 60079-30-1 eb mb IIC 226°C(T2) Gb

Ex 60079-30-1 tb IIIC T226°C Db or Ex 60079-30-1 mb tb IIIC T226°C Db

Tmin -60°C

The KTV heating cables are approved by DNV for use on ships and mobile off shore units.

DNV Certificate No. DNV-GL TAE00000TV



TC RU C-BE.MЮ62.B.00054/18

1Ex e IIC 226°C (T2) Gb X 1Ex e mb IIC 226°C (T2) Gb X

Ex tb IIIC T226°C Db X Ex tb mb IIIC T226°C Db X

Ta -60°C...+56°C IP66

000 "ТехИмпорт"



Ex e IIC 226°C (T2) Gb

Ex tD A21 IP66 T226°C

SPECIFICATIONS

Maximum maintain or continuous exposure temperature (power on) 150°C

Maximum intermittent exposure temperature (power on/off) 250°C (*)
Maximum cumulative exposure 1000 hours
(*) The 250°C rating applies to all products printed "MAX INTERMITTENT EXPOSURE 250C".

Temperature classification T2

Based on systems approach* T3-T6
* nVent RAYCHEM KTV heat-tracing cables are approved for the listed temperature classifications by using the principles of stabilized design (as per system classification approach) or the use of a temperature limiting device.
Use TraceCalc design software or contact nVent.

Minimum installation temperature -60°C

Minimum bend radius
-60°C ≤ T < -20°C: 26
-20°C ≤ T < -10°C: 20
-10°C ≤ T < 0°C: 15
0°C ≤ T < +10°C: 15
T ≥ +10°C: 12

THERMAL OUTPUT RATING

Nominal power output at 230 Vac on insulated steel pipes

- A 20KTV2-CT**
- B 15KTV2-CT**
- C 8KTV2-CT**
- D 5KTV2-CT**

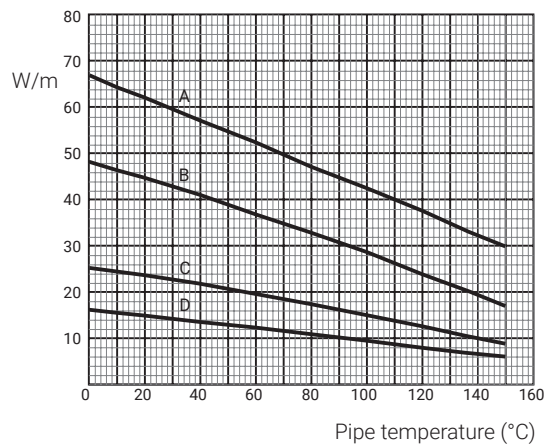

	5KTV2-CT	8KTV2-CT	15KTV2-CT	20KTV2-CT
Nominal power output (W/m at 10°C)	16	25	47	66

PRODUCT DIMENSIONS (NOMINAL) AND WEIGHT

Thickness (mm)	7.6	7.6	7.6	7.6
Width (mm)	13.3	13.3	13.3	13.3
Weight (g/m)	250	250	250	250

MAXIMUM CIRCUIT LENGTH BASED ON TYPE 'C' CIRCUIT BREAKERS ACCORDING TO EN 60898

Electrical protection sizing	Start-up temperature	Maximum heating cable length per circuit (m)			
16 A	-20°C	130	95	60	40
	+10°C	145	105	65	45
25 A	-20°C	205	150	90	65
	+10°C	230	165	100	75
32 A	-20°C	230	180	115	85
	+10°C	230	180	130	95
40 A	-20°C	230	180	130	105
	+10°C	230	180	130	110

The above numbers are for circuit length estimation only. For more detailed information please use the nVent RAYCHEM TraceCalc software or contact your local nVent representative. nVent requires the use of a 30 mA residual current device to provide maximum safety and protection from fire.

Where design results in higher leakage current, the preferred trip level for adjustable devices is 30 mA above any inherent capacitive leakage characteristic of the heater as specified by the trace heater supplier or alternatively, the next common available trip level for non adjustable devices, with a maximum of 300 mA. All safety aspects need to be proven.

ORDERING DETAILS

Part description	5KTV2-CT	8KTV2-CT	15KTV2-CT	20KTV2-CT
Part No.	P000001679	P000001681	P000001683	P000001685

COMPONENTS

nVent RAYCHEM offers a full range of components for power connections, splices and end seals.

These components must be used to ensure proper functioning of the product and compliance with electrical requirements.

North America

Tel +1.800.545.6258
Fax +1.800.527.5703
thermal.info@nVent.com

Europe, Middle East, Africa

Tel +32.16.213.502
Fax +32.16.213.604
thermal.info@nVent.com

Asia Pacific

Tel +86.21.2412.1688
Fax +86.21.5426.3167
cn.thermal.info@nVent.com

Latin America

Tel +1.713.868.4800
Fax +1.713.868.2333
thermal.info@nVent.com



Our powerful portfolio of brands:

CADDY ERICO HOFFMAN RAYCHEM SCHROFF TRACER