

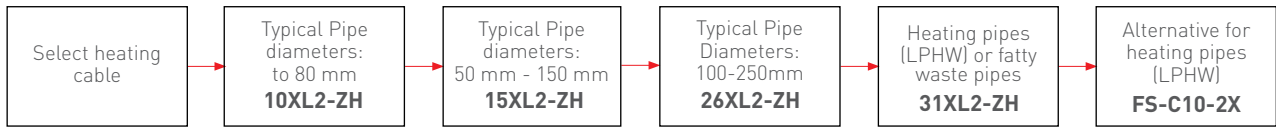

# Raychem DESIGN OVERVIEW: PIPE FREEZE PROTECTION AND FLOW MAINTENANCE OF GREASY WASTE PIPES

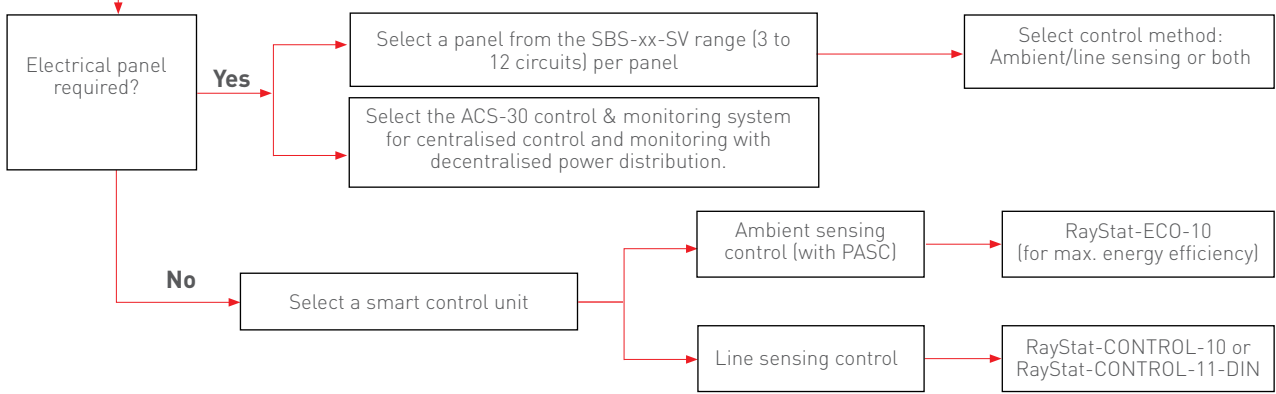

\* Note: The exact power loss from the pipe can be calculated using TraceCalc Pro for Buildings. Pipe heat loss is influenced by other factors including pipe material, insulation type and thickness, as well as ambient temperature.

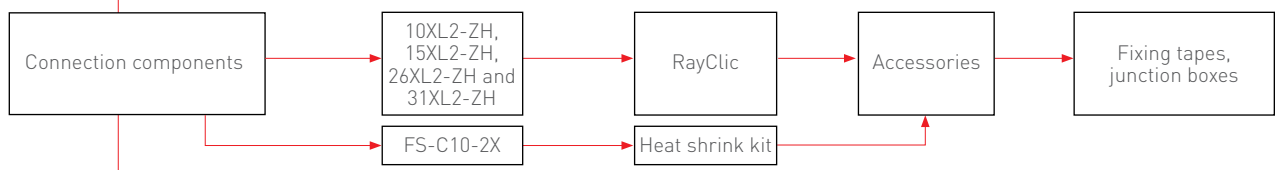
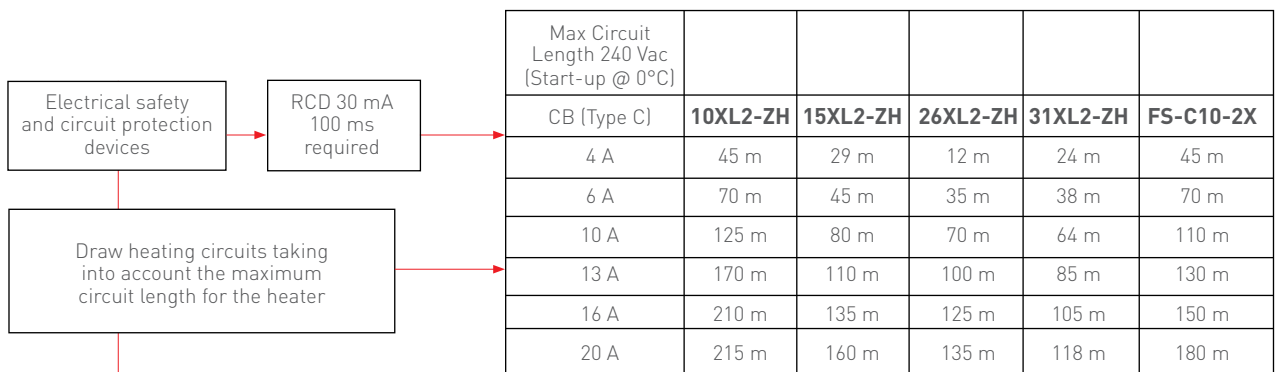
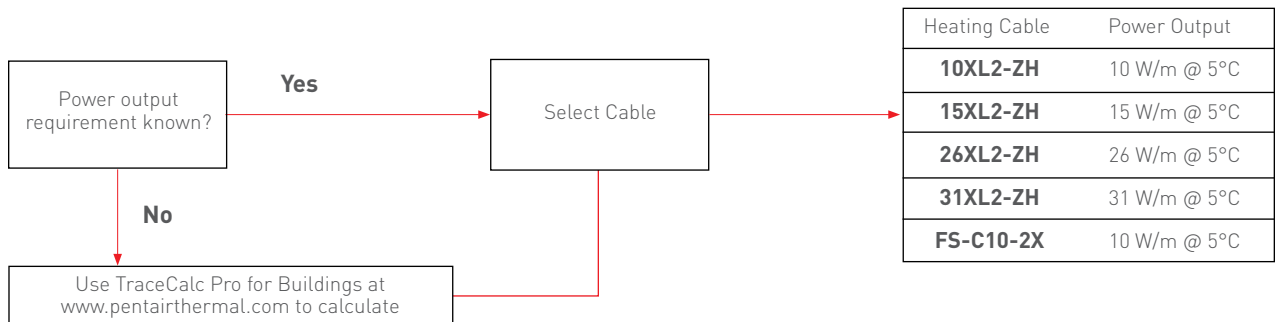



[WWW.PENTAIRTHERMAL.COM](http://WWW.PENTAIRTHERMAL.COM)

**UNITED KINGDOM**

Tel: 0800 969 013  
Fax: 0800 968 624  
[salesthermalUK@pentair.com](mailto:salesthermalUK@pentair.com)

**IRELAND**

Tel: 1800 654 241  
Fax: 1800 654 240  
[salesIE@pentair.com](mailto:salesIE@pentair.com)

**AUSTRALIA**

Tel: +61 2 97920250  
Fax: +61 2 97745931  
[sales.thermal@pentair.com](mailto:sales.thermal@pentair.com)

**INDIA - NOIDA**

Tel: +91 120 464 9500  
Fax: +91 120 464 9548  
[PTMinfome@pentair.com](mailto:PTMinfome@pentair.com)

**INDIA - MUMBAI**

Tel: +91 22 6775 8800/01  
Fax: +91 22 2556 1491  
[PTMinfome@pentair.com](mailto:PTMinfome@pentair.com)

**UAE**

Tel: +971 4 378 1700  
Fax: +971 4 378 1777  
[PTMinfome@pentair.com](mailto:PTMinfome@pentair.com)

**SOUTH EAST ASIA**

Tel: +65 67685800  
Fax: +65 67322263  
[sales.thermal@pentair.com](mailto:sales.thermal@pentair.com)

Pentair is owned by Pentair or its global affiliates. All other trademarks are the property of their respective owners. Pentair reserves the right to change specifications without prior notice.

© 2017 Pentair.

